

Ugaoni element ; D400

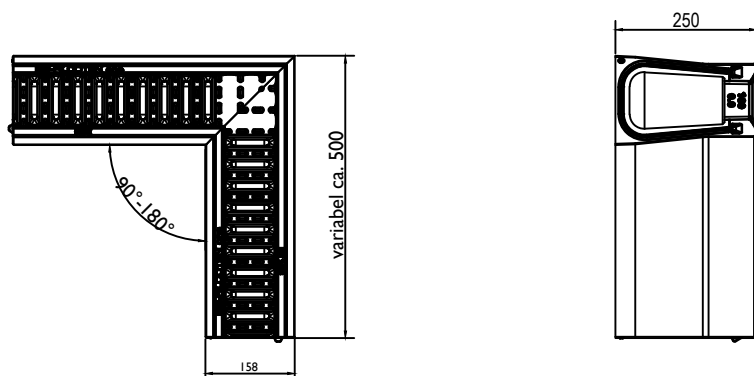

Ugaoni element - Dimenzije [mm]						
BG code	Tip	Visina A	Visina B	Dužina	Težina [kg]	SW
15110000	0	250	250	var.	ca. 36	10/70

Izlivna jedinica sa vertikalnim bušenjem DN 100 (bočno bušenje opcionalno); D400

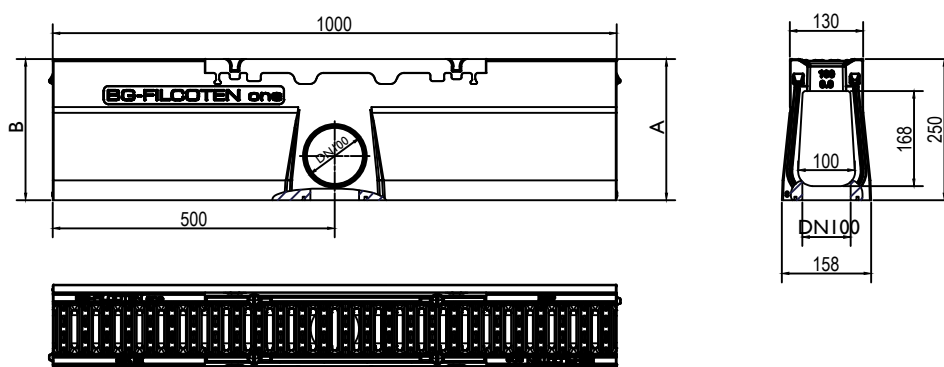

Izlivna jedinica - Dimenzija [mm]							
BG code	Tip	Visina A	Visina B	Dužina	Ulazni presek [cm ² /m]	Težina [kg]	SW
15110190	0	250	250	1000	195	41	10/70

purator
serbia
member of the waliner & neubert group

PURATOR Ekotehnika d.o.o.

ul. Kružni put 16a
Beograd, Leštane
office@purator.rs

tel.: +381 11 803 10 52
faks: +381 11 803 08 26
www.purator.rs



www.bg-company.com

Naziv crteža: **LINIJSKO ODVODNJAVANJE-FCT one urban NW100-ugaoni element, izlivna jedinica**
Drawing name:

Art.br:

15110000
15110190

format:

A4

scale: