

LEGENDA

1	REGULATOR PROTOKA
2	KOALESCENTNI FILTER
3	PLOVAK
4	BY-PASS
5	BETONSKI REZERVOAR
6	BETONSKA PLOČA
7	ŠAHT
8	POKLOPAC DN 600

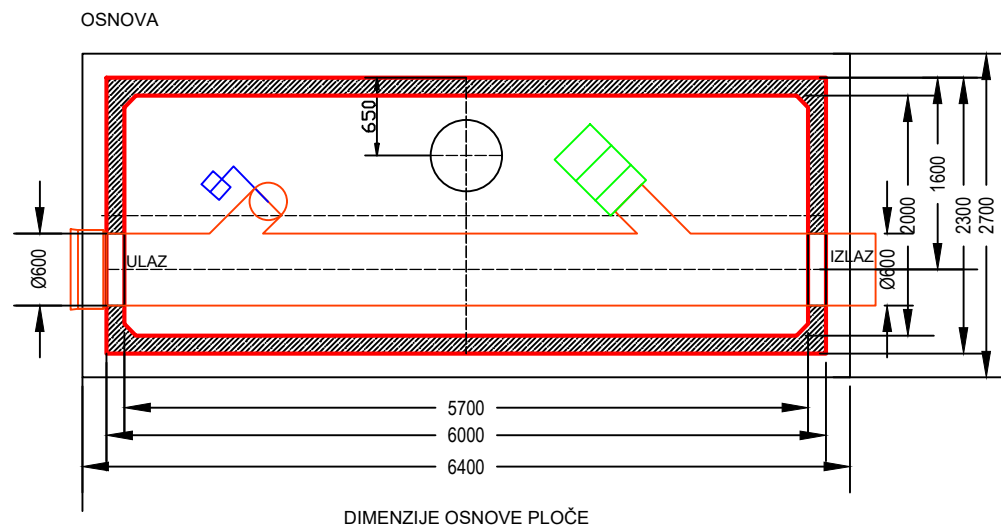

OPŠTE

KLASA OPTEREĆENJA 15kN-400kN
TEŽINA NAJTEŽEG DELA 12 T
UKUPNA TEŽINA 24 T
H= UKUPNA DUBINA
h=DUBINA OD PLOČE DO ŠAHTA
KAPACITET TALOŽNIKA 11.3 m ³
EFEKTIVNI KAPACITET 16.8 m ³
PROTOK 100 l/s
UKUPNI PROTOK 500 l/s
IZLAZNE VREDNOSTI 5 mg/l NEL

purator
serbia
member of the wallner & neubert group

PURATOR Ekotehnika d.o.o.
ul. Kružni put 16a
Beograd, Leštane
office@purator.rs

tel.: +381 11 803 10 52
faks: +381 11 803 08 26
www.purator.rs

V-ALFATEC
the key to clean water

V-Alfatec, s.r.o.
Kátlovce 303, 919 55
Prev.:Niklová ul. 4346
926 01 Sered'
tel/fax: 031/780 59 00
mail: v-alfatec@mail.t-com.sk
web: www.v-alfatec.sk

Naziv crteža: **SEPARATOR ULJA LO ALFA100-500B, taložnik 11.3m³**
Drawing name:

Art.br: 89000133

Typ: LO ALFA 100-500B