

FCT tec NW 100

1. Kanal: tec NW100 V

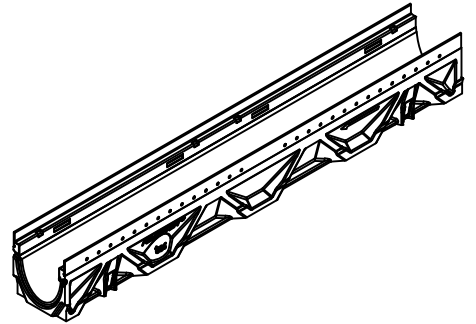
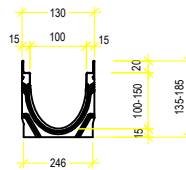
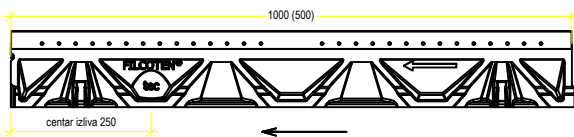

2. Liveno gvozdена rešetka/mrežasta:

C250kN MW29/13: GJS 17010101

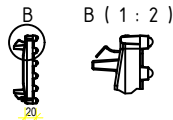
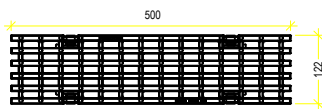

C250kN MW29/6: GJS 17010106



3. Sabirno okno:

(opcionalno: sifon DN 150: 30056, kofica za sabirno okno 22515

V 10410291

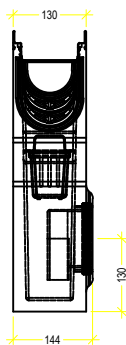
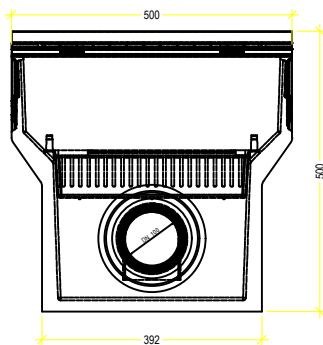

4. Čeoni poklopac/Čeoni poklopac sa izlivom:

V 19010230

V 19010231

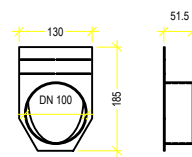
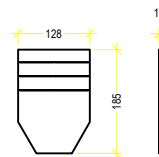

5. Anti-vandal sistem za zaključavanje rešetki NW 150 32087:



Kanal - dimenzije				
Tip	visina A	visina B	dužina	BG code V
mini 80	80	80	1000	10210201
0	135	135	1000	10410200
0 (0,5m)	135	135	500	10410250
1	135	140	1000	10410201
2	140	145	1000	10410202
3	145	150	1000	10410203
4	150	155	1000	10410204
5	155	160	1000	10410205
5-0	160	160	1000	10410261
6	160	165	1000	10410206
7	165	170	1000	10410207
8	170	175	1000	10410208
9	175	180	1000	10410209
10	180	185	1000	10410210
10-0	185	185	1000	10410262

Legenda:	
V:	počinkovani čelik (ivica)
E:	nerđajući čelik
GJS:	liveno gvožđe
H:	drvo

purator
serbia
member of the wallner & neubert group

PURATOR Ekotehnika d.o.o.
ul. Kružni put 16a
Beograd, Leštane
office@purator.rs
tel.: +381 11 803 10 52
faks: +381 11 803 08 26
www.purator.rs



www.bg-company.com

Naziv crteža:
Drawing name:

LINIJSKO ODVODNJAVANJE-FCT tec NW100

Art.br:

10410200

format:

A4

scale: