

FCT pro NW 150  
Rešetke:

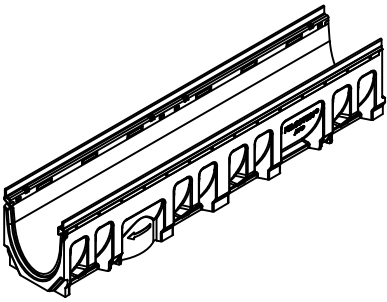

1. Mrežasta rešetka:

B125kN MW30/10: V 17015220 (17015221)

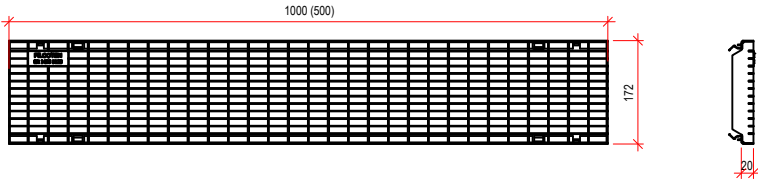

C250kN MW30/10: V 17015222 (17015223), E 17015322 (17015323)

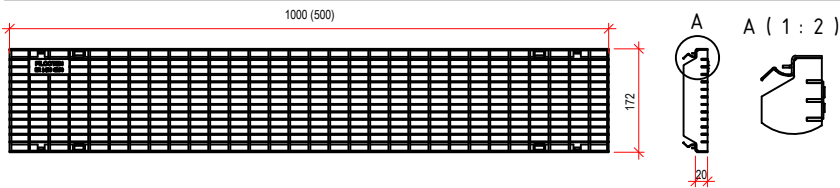

D400kN MW25/10: V 17015226 (17015227), E 17015326 (17015327)

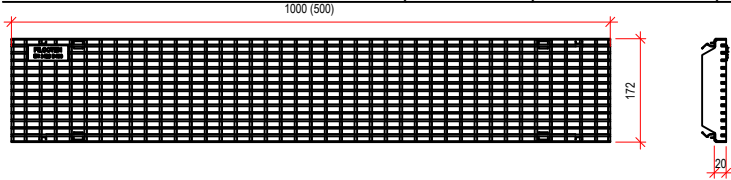

2. Liveno gvozdene rešetke:

C250kN MW29/13: GJS 17015101

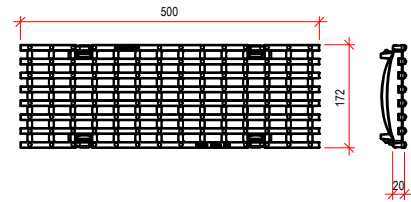

D400kN MW29/13: GJS 17015104

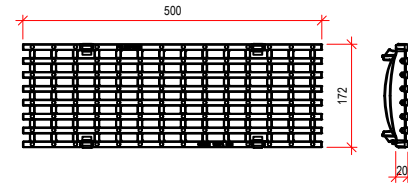

E600kN SW14/150: GJS 17015105

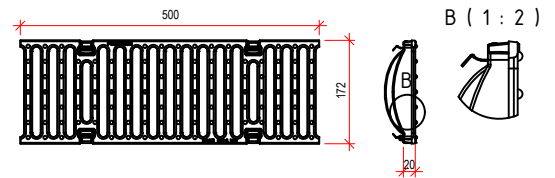

E600kN MW22/13: GJS 17015103

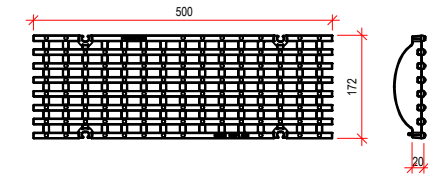

F900kN SW14/150: GJS 17015107, sa 4 šrafa

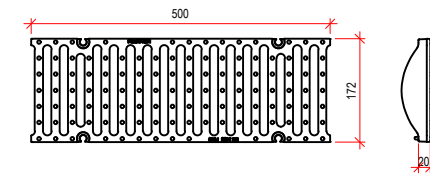

Rešetke-pro	
Mrežasta rešetka	
MW 30/10, 1000(500)/172/20, kl B 125kN V	17015220
MW 30/10, 1000(500)/172/20, kl C 250kN V, E	17015222
MW 25/10, 1000(500)/172/20, kl D 400kN V,E	17015226
Liveno gvozdene rešetke	
MW 29/13, 500/172/20, kl C 250kN GSJ.fix	17015101
MW 29/13, 500/172/20, kl D 400kN GSJ.fix	17015104
SW 14/150, 500/172/20, kl E 600kN GSJ.fix	17015105
MW 22/13, 500/172/20, kl E 600kN GSJ.fix	17015103
SW 14/150, 500/172/20, kl F 900kN GSJ.fix	17015107

Legenda:	
V:	pocinkovani čelik (tvica)
E:	nerđajući čelik
GJS:	liveno gvožđe
H:	drvo

**purator**  
serbia  
member of the waltner & neubar group

PURATOR Ekotehnika d.o.o.  
ul. Kružni put 16a tel.: +381 11 803 10 52  
Beograd, Leštane faks: +381 11 803 08 26  
office@purator.rs www.purator.rs



www.bg-company.com

Naziv crteža:  
Drawing name:

**LINIJSKO ODVODNJAVANJE-FCT pro NW150-rešetke**

Art.br:

format:

A4

scale: