

FCT pro NW 150 mini

1. Kanal:

pro NW150 mini 100/120 V-E

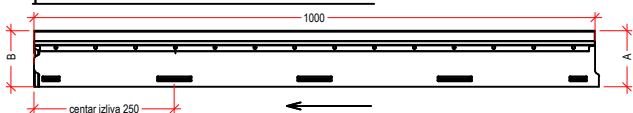

pro NW150 mini 100/120 G

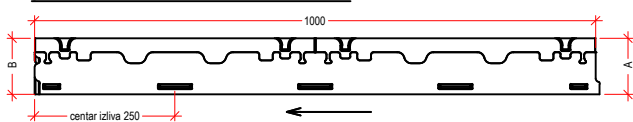

pro NW150 mini 170 V-E

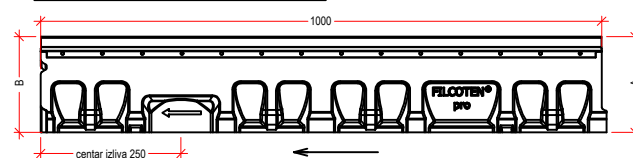

pro NW150 mini 170 G

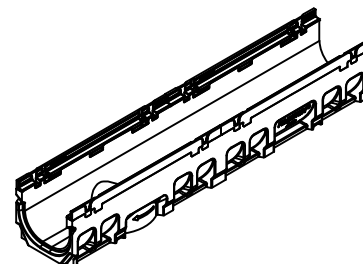
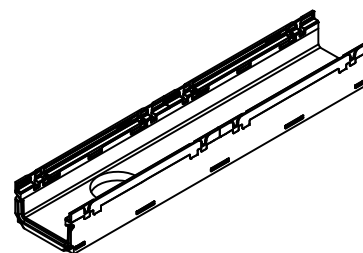
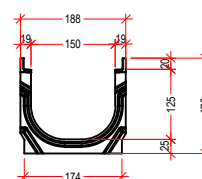
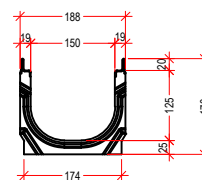
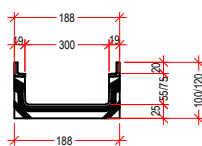
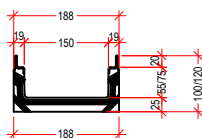
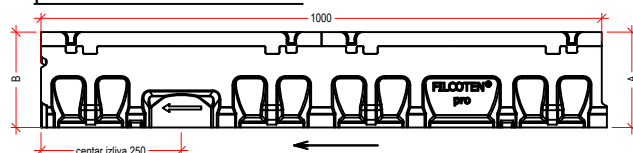

2. Mrežasta rešetka:

C250kN MW30/10: V 17015222 (17015223), E 17015322 (17015323)

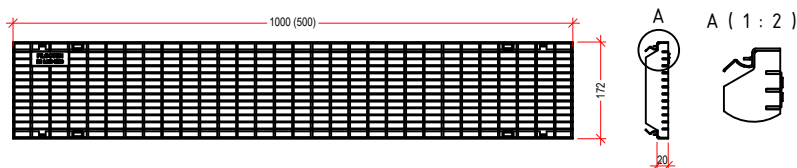

3. Sabirno okno:

V 10615290, E 10615390

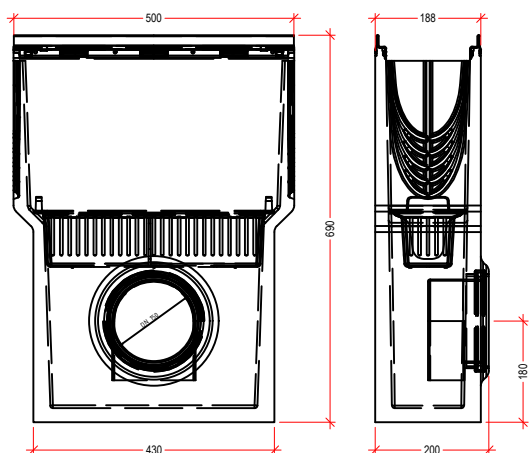

4. Čeoni poklopac mini:

V 19015200, E 19015300

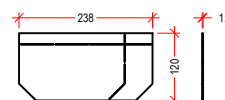

5. Antivandal uređaj za zaključavanje:

32088



Kanal - dimenzije

Tip	visina A	visina B	dužina	BG code V	BG code E	BG code G
mini 100	100	100	1000	10515202	10515302	10515102
mini 120	120	120	1000	10515200	10515300	10515100
mini 170	170	170	1000	10515201	10515301	10515101

Legenda:	
V:	pocinkovani čelik (ivica)
E:	nerđajući čelik
GJS:	liveno gvozdje
H:	drvo



PURATOR Ekotehnika d.o.o.

ul. Kružni put 16a
Beograd, Leštane
office@purator.rs

tel.: +381 11 803 10 52
faks: +381 11 803 08 26
www.purator.rs



www.bg-company.com

Naziv crteža:

Drawing name:

LIJIJSKO ODVODNJAVANJE-FCT pro NW150 mini

Art.br:

10515202

format:

A4

scale: