

## FCT pro NW 100 mini

### 1. Kanal: pro NW100 mini 60/80 V-E

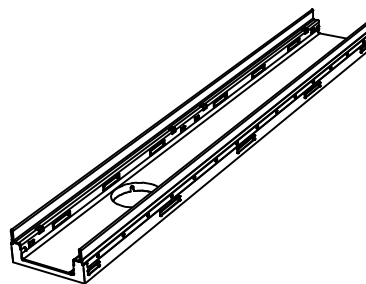

### pro NW100 mini 80 G

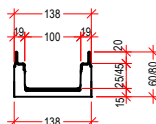
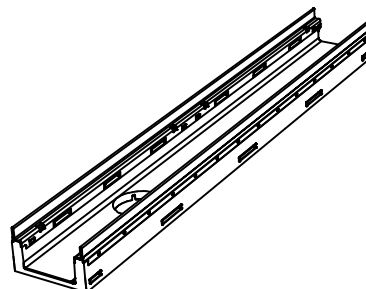
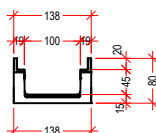
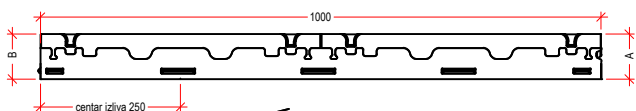

### 2. Mrežasta rešetka:

C250kN MW30/10: V 17010222 (17010223), E 17010322 (17010323)

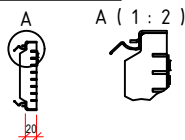
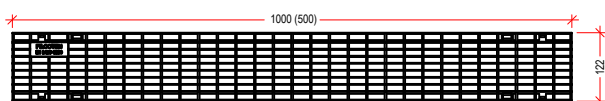

### 4. Čeoni poklopac mini:

V 19010200, E 19010300

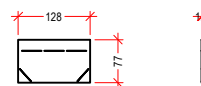

### 5. Antivandal uređaj za zaključavanje:

32087

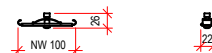

### 6. Kofica za sabirno okno:

PVC 30019

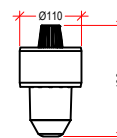

### 3. Sabirno okno:

(opcionalno: kofica za sabirno okno 22515  
V 10610290, E 10610390)

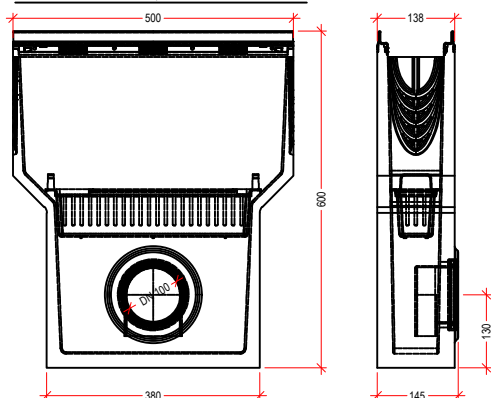

Kanal - dimenzije						
Tip	visina A	visina B	dužina	BG code V	BG code E	BG code G
mini 60	60	60	1000	10510200	10510300	-
mini 80	80	80	1000	10510201	10510301	10510101

Legenda:	
V:	pocinkovani čelik (ivica)
E:	nerđajući čelik
GJS:	liveno gvožđe
H:	drvo

**purator**  
serbia  
member of the wallner & neubert group

PURATOR Ekotehnika d.o.o.  
ul. Kružni put 16a  
Beograd, Leštane  
office@purator.rs  
tel.: +381 11 803 10 52  
faks: +381 11 803 08 26  
www.purator.rs



www.bg-company.com

Naziv crteža:  
Drawing name:

**LINIJSKO ODVODNJAVANJE-FCT pro NW100 V-E**

Art.br:

10610200

format:

A4

scale: