

1. Kanal:  
light NW150

FCT light NW 150

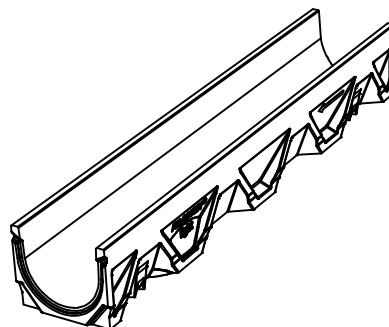

2. Liveno gvozdена rešetka: C250 MW15/28 GSJ 17015100

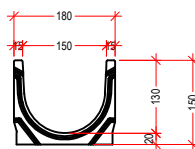
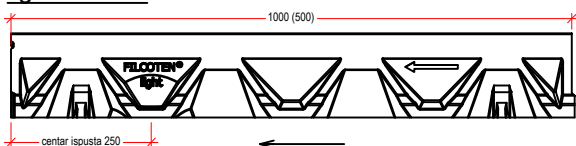
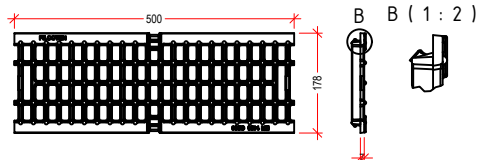

3. Sabirno okno:  
V 10315091

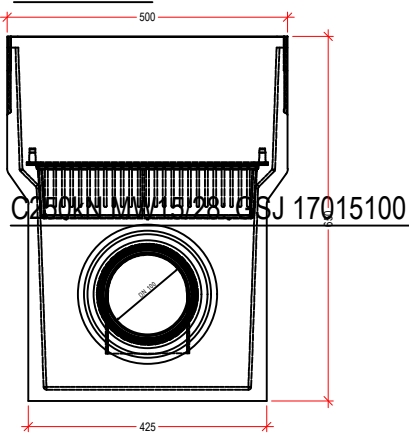

4. Čeoni poklopac/Čeoni poklopac sa izlivom:  
V 19015230; E19015330 V 19015232; E19015332

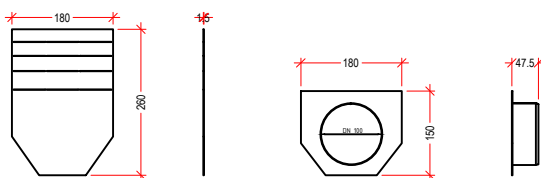

6. Element za zaključavanje za  
liveno gvozdenu rešetku: 32067



6. Element za zaključavanje za  
mrežastu rešetku: 32080

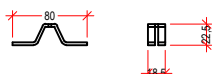

Element za povezivanje za liveno  
gvozdenu mrežastu rešetku 32068

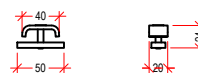

Kanal/dimenzije				
Tip	Visina A	Visina B	Dužina	BG code
0	150	150	1000	10315000
0 (0,5m)	150	150	500	10315050

Legenda:	
V:	pocinkovani čelik (ivica)
E:	nerđajući čelik
GJS:	liveno gvožđe
H:	drvo

**purator**  
serbia  
member of the wallner & neubert group

PURATOR Ekotehnika d.o.o.  
ul. Kružni put 16a tel.: +381 11 803 10 52  
Beograd, Leštane faks: +381 11 803 08 26  
office@purator.rs www.purator.rs



www.bg-company.com

Naziv crteža:  
Drawing name:

**LINIJSKO ODVODNJAVANJE-FCT light NW150**

Art.br: 10315000

format: A4  
scale: